

# BarrierGate® Retrofit Jack Installation Addendum

## **1200 LB RETROFIT JACK ASSEMBLY**

**Be sure to disconnect any power source to the gate before doing any work on the System.**

Some models of the BarrierGate have a 115VAC actuator attached to the Manual Jack Assembly. Manual Systems have a steel bar in place of the Actuator.

Open the Manual Jack Access Cover located at the middle of the Gate. Locate and remove the black Safety Guard mounting bolt, washer and nut. Swing the Safety Guard out of the way. Remove the  $\frac{3}{4}$ " x 6  $\frac{1}{2}$ " retaining pin and cotter; this will release the Jack Assembly. With the Manual Drive Handle, run the Body forward about 6" and remove the second  $\frac{3}{4}$ " x 6  $\frac{1}{2}$ " pin and cotter; this will release the actuator/bar. Run the Jack Assembly back 5". The Actuator/Bar will drop a few inches. Collect all lose parts and set aside for later installation.

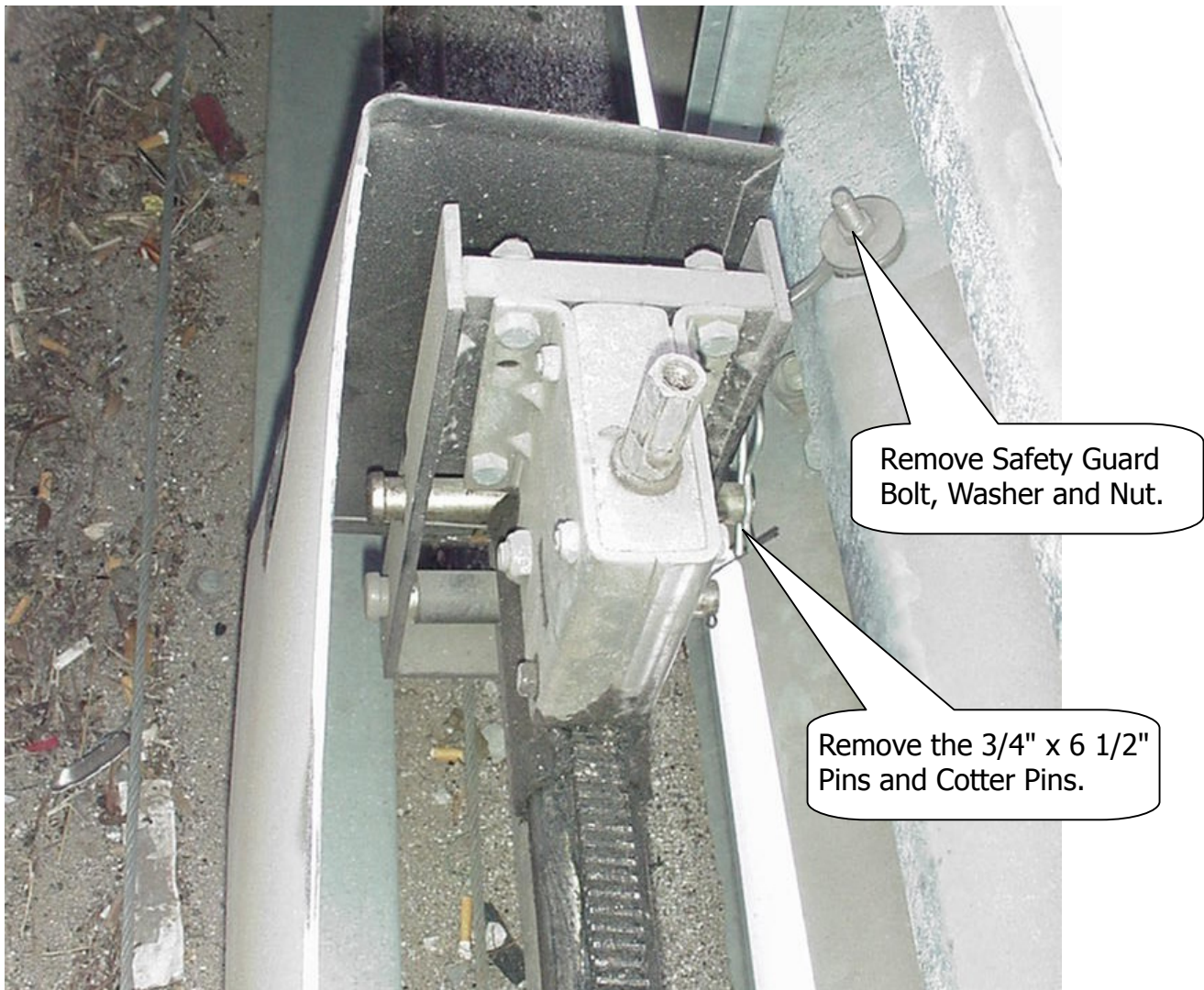

# BarrierGate® Retrofit Jack Installation Addendum

Move to the other end of the jack assembly and locate the two 3/8" x 2" Hex Head bolts, lock washers and nuts. Remove them from the assembly and set aside. The Jack Assembly should be loose and free to be removed by moving the assembly away from the Bulkhead. As you move the Jack Assembly back and off the mounting, lift it out and place it out of the way.

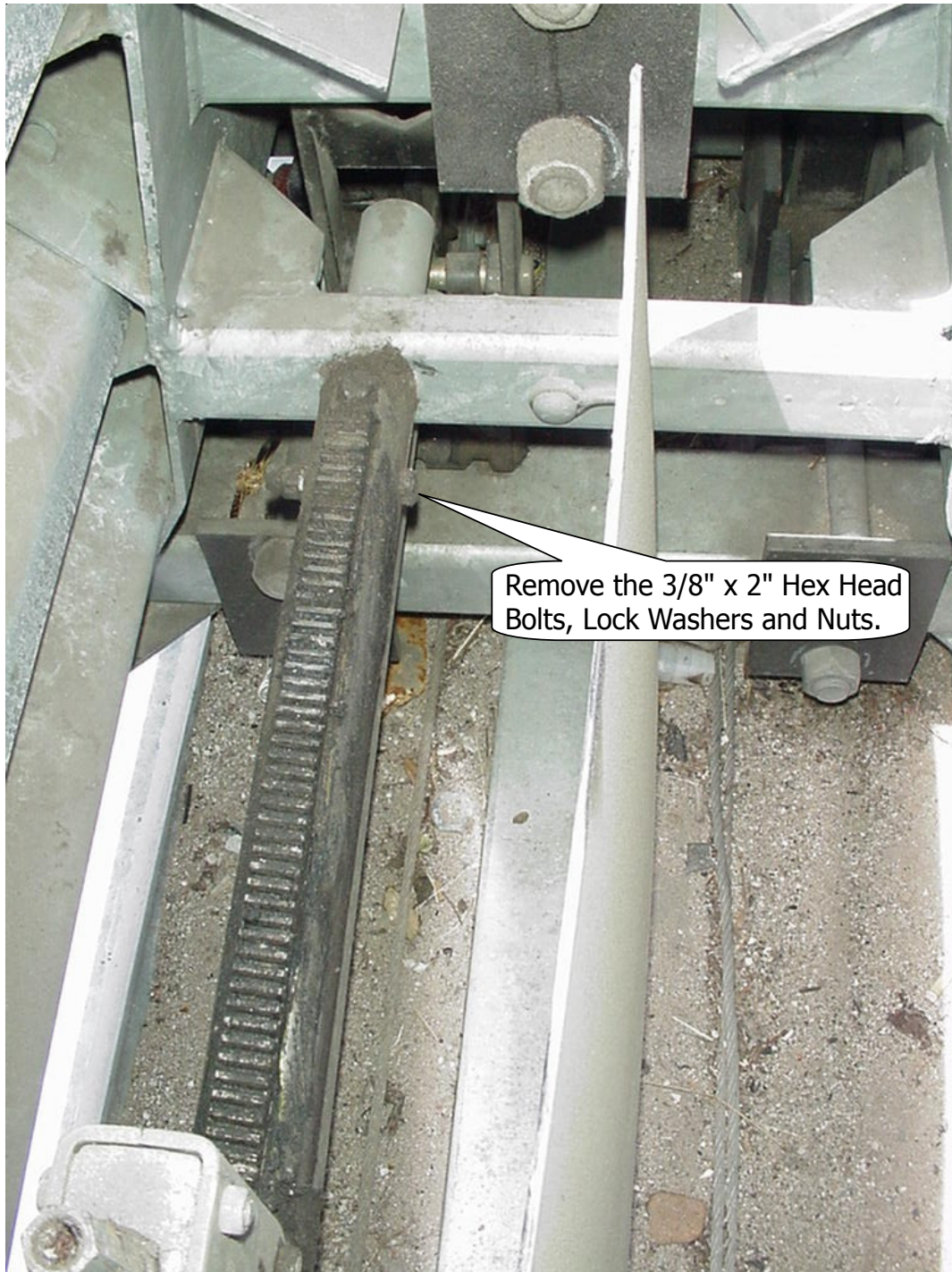



# BarrierGate® Retrofit Jack Installation Addendum

Install the new Jack Assembly by inserting it into the Bulkhead and attach the Jack Assembly to the Bulkhead with the two (2) 3/8" x 2" Hex Head bolts, Lock Washers and Nuts supplied with the assembly. Once the Jack Assembly is in place, move the Body forward with the Drive Handle and position the Actuator/Bar into the Jack Assembly. Attach the Actuator/Bar to the Support Bracket of the Jack Assembly with the second 3/4" x 6 1/2" Pin and Cotter. Move the Rear Mount Bracket against the corrugated Side Panel. Mark the position for the mounting hole, move the Bracket out of the way. Drill a pilot hole in the center of the marked hole then drill through pilot hole with a 3/4" drill. Move the rear bracket over the hole and attach with the GR 5/8 x 1 1/4 bolt and nut. With the Jack Assembly secured to the System, place the Jack Handle on the Drive and move the Jack Head back and forth. Drive the Jack Head against the Rear Bracket and insert the Locking Pin and secure it. Return the Jack Handle to it's storage location and close the lid.

Insert Jack Assembly into the Bulkhead Mounting and attach with 3/8" x 2" Hex Head Bolts, Washers and Nuts.

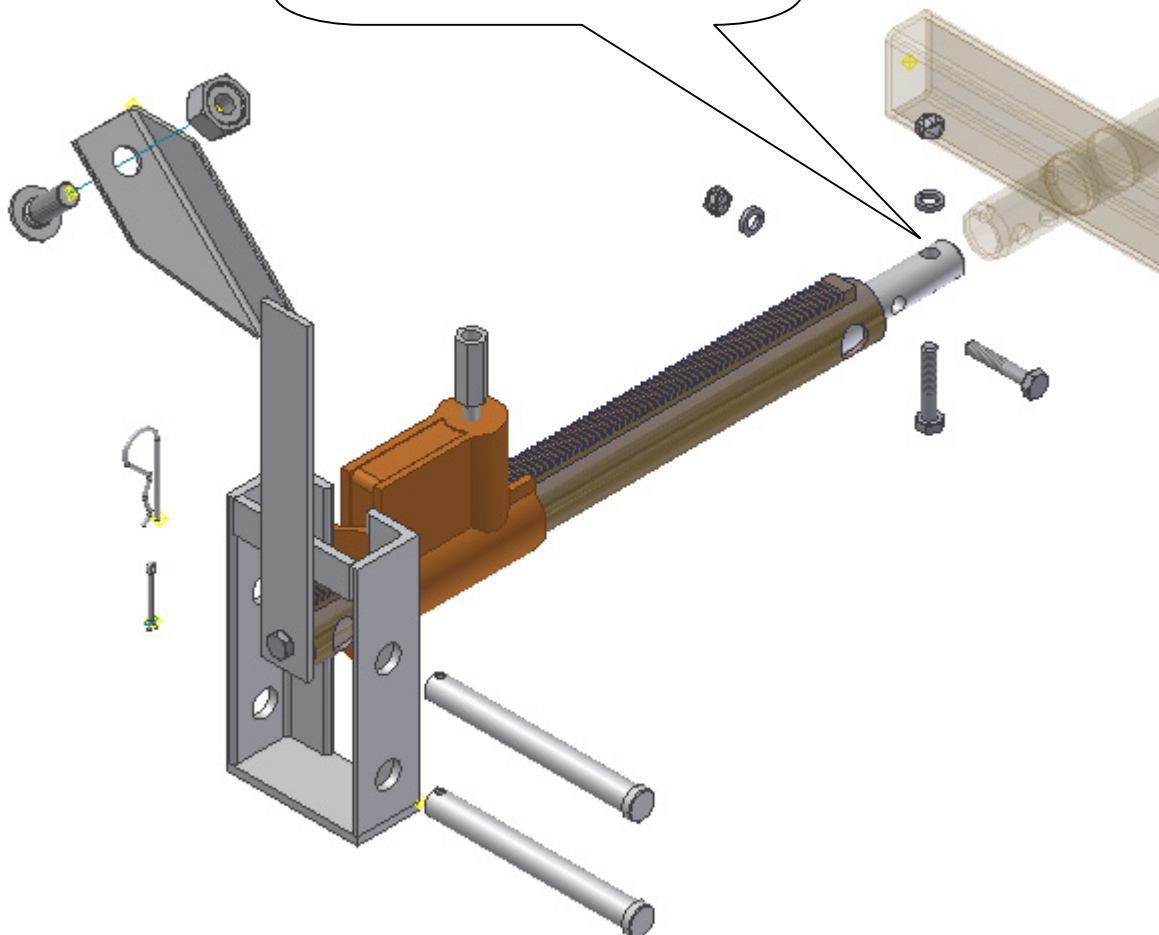

# BarrierGate® Retrofit Jack Installation Addendum

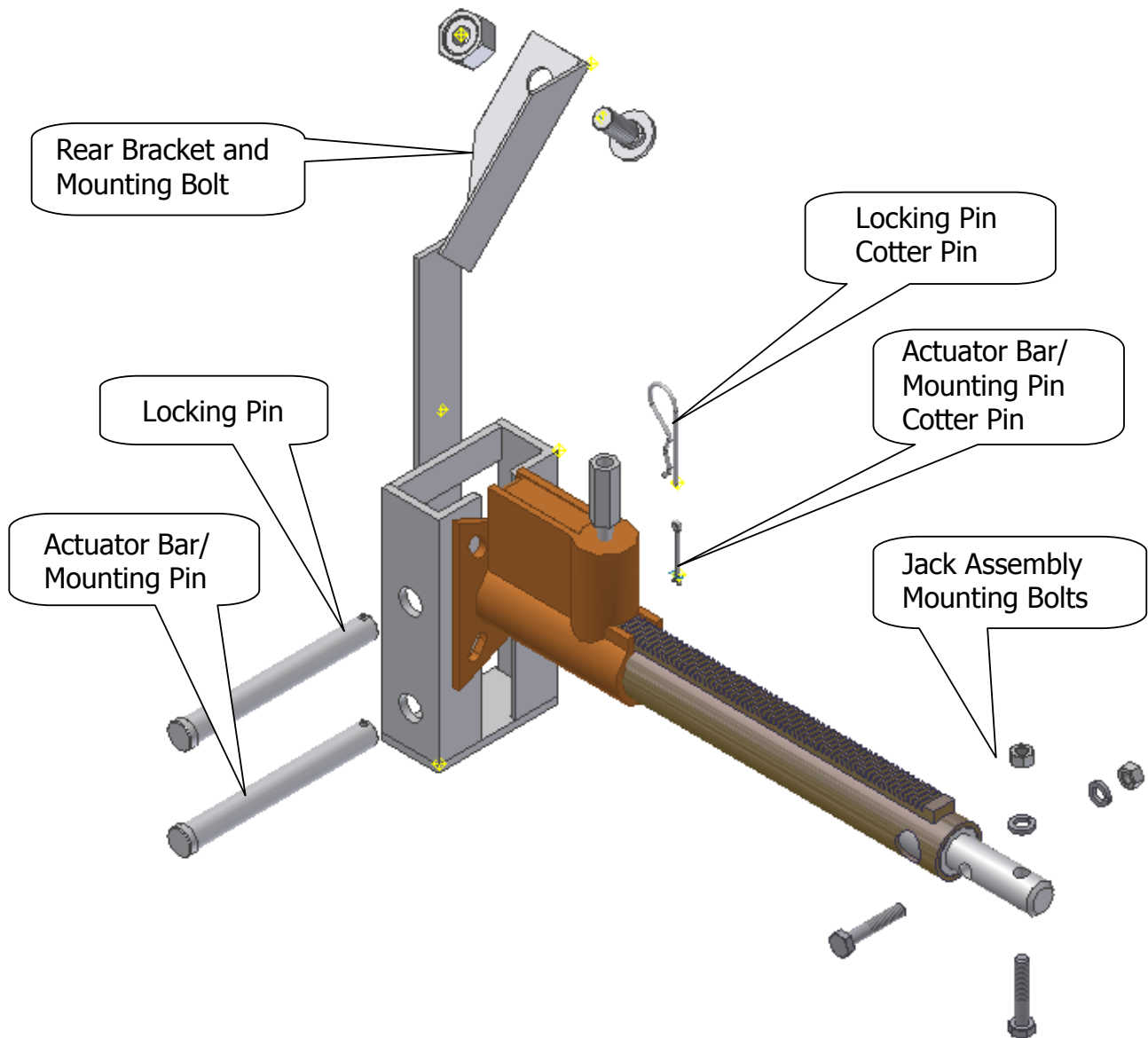

*Retrofit 1200 lb. Jack Assembly*